



CHANTLAND

M H S

Material Handling Solutions

Since
1943

BAG CLOSING

4214 HEAVY DUTY BELT CONVEYOR

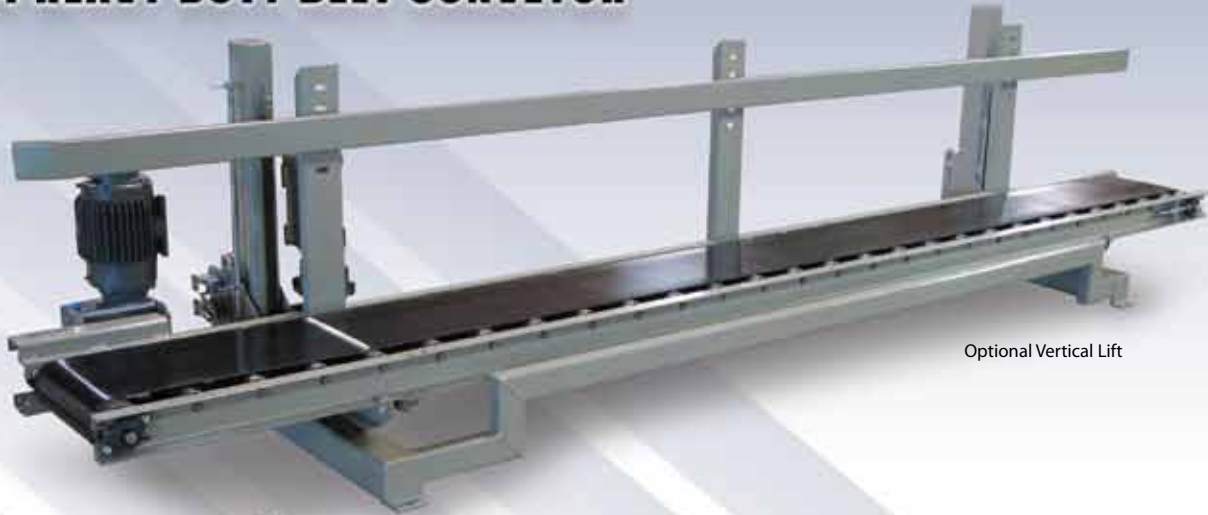

Optional Vertical Lift



Optional Wire Mesh Belt



Roller bed conveyor for use in transferring filled bags in an upright position through a closing system such as heat sealer or sewing head.

SOLUTIONS

WWW.CHANTLAND.COM

BAG FILLERS + CONVEYERS + PALLETIZERS + SYSTEMS

BAG CLOSING

4214 HEAVY DUTY BELT CONVEYOR

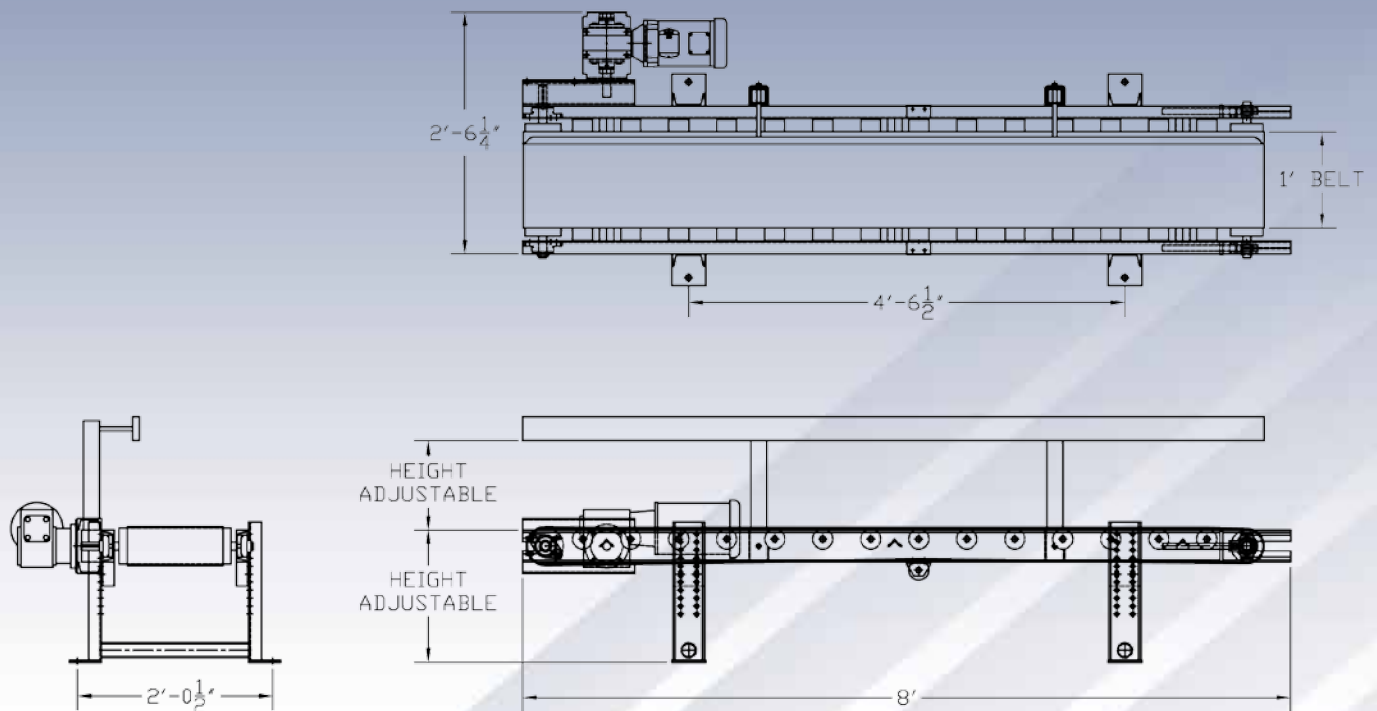

DESIGN FEATURES:

- ✦ Conveys paper, poly and jute bags.
- ✦ 12" wide PVC conveyor belt.
- ✦ 8' overall standard conveyor length.
- ✦ 35 FPM standard belt speed.
- ✦ Adjustable bag rail full length on backside of conveyor.
- ✦ Lagged drive pulley for maximum belt traction.
- ✦ Supports adjustable for 12"-20" top of belt height.
- ✦ NEMA 12 electrical controls: 230/460 V., 60 Hz., 3 Ph.
- ✦ Structural channel mild steel roller bed conveyor frame.
- ✦ Industrial enamel finish.



Optional foot operated start/stop switch

AVAILABLE FEATURES:

- ✦ Manual or electric vertical lift assembly.
- ✦ Lengths and heights to meet specific applications.
- ✦ Supports with locking casters.
- ✦ Foot operated start/stop switch.
- ✦ Variable speed controls.
- ✦ Wash down, corrosive and explosion proof electrical packages.
- ✦ Stainless steel construction.
- ✦ Galvanized or stainless steel wire mesh conveyor belt.
- ✦ Plastic conveyor belt.
- ✦ Special finish coatings.

BAG FILLERS

CONVEYORS

PALLETIZERS

SYSTEMS

PO Box 279, Humboldt, Iowa, U.S.A. 50548 / Ph. 515.332.4045 Fax 515.332.1502

www.chantland.com