

# SWECO®

## MACON™ SEPARATORS

### AFFORDABLE RELIABILITY . . . SIMPLE DESIGN

**D**esigned for those users who are searching for a more cost effective alternative for processing materials, the Macon™ Separator delivers rock-solid value. Supplying sturdy, reliable components, the Macon Separator's straight-forward design handles the needs of most simple screening applications, including scalping, sizing and dedusting. With industry standard spout heights, screen diameters and footprint, the Macon Separator is available in 30", 48" and 60" diameters in either carbon or stainless steel frame construction.

When no modifications or on-site application help is necessary, reduce your cost of buying and maintaining round separators with the Macon Separator from Sweco®, the leader in separation technology.



*We Put Technology In Motion™*

[www.sweco.com](http://www.sweco.com)

**SWECO HEADQUARTERS**, P.O. Box 1509, 8029 U.S. Highway 25, Florence, KY 41022-1509: +1 (859) 371.4360 Fax: +1(859) 283.8469  
**SWECO MACON**, 2919 Joycliff Road, Macon, GA 31211-2805: +1 (478) 745.5419 Fax: +1 (478) 741.1394  
**SWECO EUROPE S.A.**, Rue de la Recherche, 8, Parc Industriel Sud-Zone I, B-1400 Nivelles, Belgium: +32-67-893434 Fax: +32.67.214368  
**SWECO ASIA**, 63 Hillview Ave. #03-02, Lam Soon Industrial Building, Singapore 669569:+65.6762.1167 Fax: +65.6762.1313  
**SWEQUIPOS S.A. DE C.V.**, Aut. Mex-Qro, #2500 Km. 23.2, Tlalnepantla, Edo. Mexico: +52 (5) 390-07-32, Fax: +52 (5) 565-98-18

# Dependable Round Vibratory Separation Equipment!

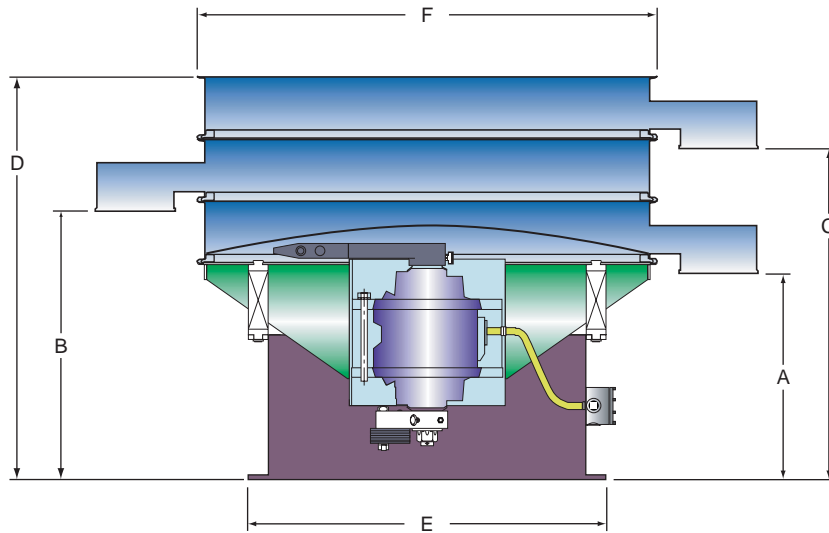

Model	A		B		C		D		E		F		Weight	
	in	mm	in	mm	in	mm	in	mm	in	mm	in	mm	lbs	kg
MA30-66	16.8	425	23.1	587			30.5	775	23.9	606	31.6	803	390	177
MA30-666	16.8	425	23.1	587	29.8	756	37.1	943	23.9	606	31.6	803	460	209
MA48-88	21.3	540	29.8	756			39.1	994	36.9	937	47.3	1,200	715	324
MA48-888	21.3	540	29.8	756	38.1	968	47.6	1,210	36.9	937	47.3	1,200	810	367
MA60-88	21.3	540	29.8	756			39.1	994	42.9	1,089	58.8	1,492	740	336
MA60-888	21.3	540	29.8	756	38.1	968	47.6	1,210	42.9	1,089	58.8	1,492	885	401

Model	Max.No.of Decks	Motor RPM	HP	Voltage*	Phase	Hz
MA30	3 (2 screens)	1200/1500/1800	0.50	230,380,460	3	50/60
MA48	3 (2 screens)	1200/1500/1800	2.00	230,380,460	3	50/60
MA60	3 (2 screens)	1200/1500/1800	2.00	230,380,460	3	50/60

\* Other Voltages Available

## SEPARATOR APPLICATIONS

Macon Separators are quality-built to get the job done, delivering efficient screening over a wide mesh range -- 2 mesh (11 mm) to 500 mesh (25 microns). Pretensioned stainless steel screens maximize energy transfer at 1200 RPM, 1500 RPM or 1800 RPM motor speeds. Designed for wet or dry processes, Macon Separators are applicable to a variety of industries and processes.

### INDUSTRIES

Wastewater  
Laundry  
Textiles  
Mineral Processing  
Bulk Chemical  
Canneries  
Packing Houses  
Food Intermediates

### PROCESSES

Scalping  
Sizing or Classifying  
Gravity Filtering  
Dewatering  
Solids Collection



**We Put Technology In Motion™**  
e-mail: info@sweco.com