



CHANTLAND

M H S

Material Handling Solutions

Since
1943

SWIVEL STACKER S-SERIES BELT CONVEYOR



Slider bed conveyor designed to elevate bags, discharging them onto boom conveyor which pivots side-to-side and also raises/lowers to facilitate manually stacking bags on pallets.



SOLUTIONS

WWW.CHANTLAND.COM

BAG FILLERS + CONVEYERS + PALLETIZERS + SYSTEMS

SWIVEL STACKER

S-SERIES BELT CONVEYOR

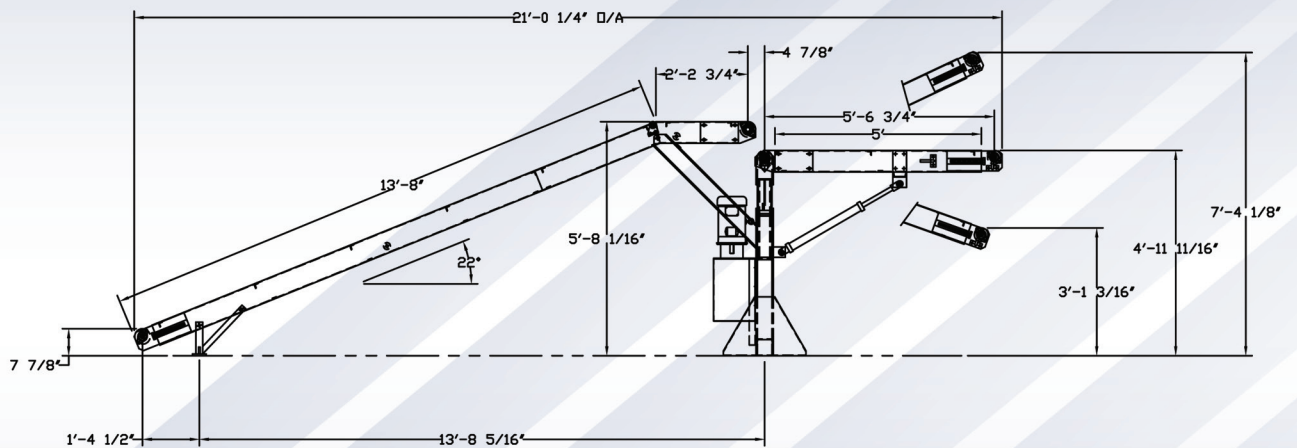
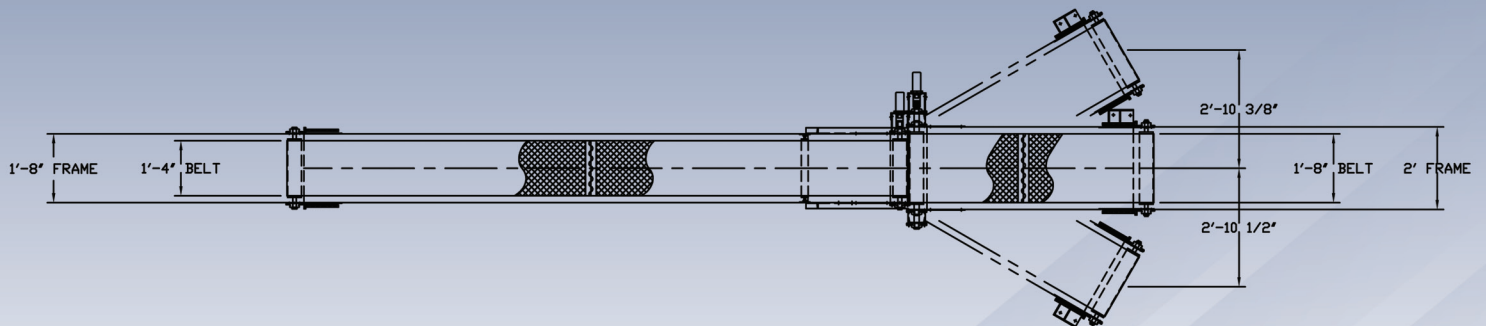

DESIGN FEATURES:

- ✦ Self-contained hydraulic system for conveyor drive motors & boom lift cylinder.
- ✦ Variable conveyor belt speed through user friendly flow controls.
- ✦ Boom height control mounted at discharge end for easy user adjustment.
- ✦ Boom pivots easily to 30 degrees from centerline for stacking multiple pallets.
- ✦ Rubber covered drive pulleys for maximum belt traction.
- ✦ Rough top belts to grip paper and poly bags.
- ✦ Formed mild steel conveyor frame.
- ✦ Industrial enamel finish.

AVAILABLE FEATURES:

- ✦ Structural channel, roller bed frame design for severe applications.
- ✦ Bag Flattener Conveyor design.
(See Model 4215 Bag Flattener Conveyor Brochure)
- ✦ NEMA 12 electrical controls: 230/460 V., 60 Hz, 3 Ph.
- ✦ Wash-down, corrosive and explosion proof electrical packages.
- ✦ Stainless steel construction.
- ✦ Special finish coatings such as epoxy and powder coat.

BAG FILLERS

CONVEYORS

PALLETIZERS

SYSTEMS

PO Box 279, Humboldt, Iowa, U.S.A. 50548 / Ph. 515.332.4045 Fax 515.332.1502

www.chantland.com