



# CHANTLAND

M H S

Material Handling Solutions

*Since  
1943*

## BAG CLOSING

### 4201 BELT CONVEYOR



Optional Vertical Lift



Medium duty belt conveyor designed to convey filled bags in an upright position through the closing system.

# SOLUTIONS

[WWW.CHANTLAND.COM](http://WWW.CHANTLAND.COM)

BAG FILLERS + CONVEYERS + PALLETIZERS + SYSTEMS

# BAG CLOSING

## 4201 BELT CONVEYOR

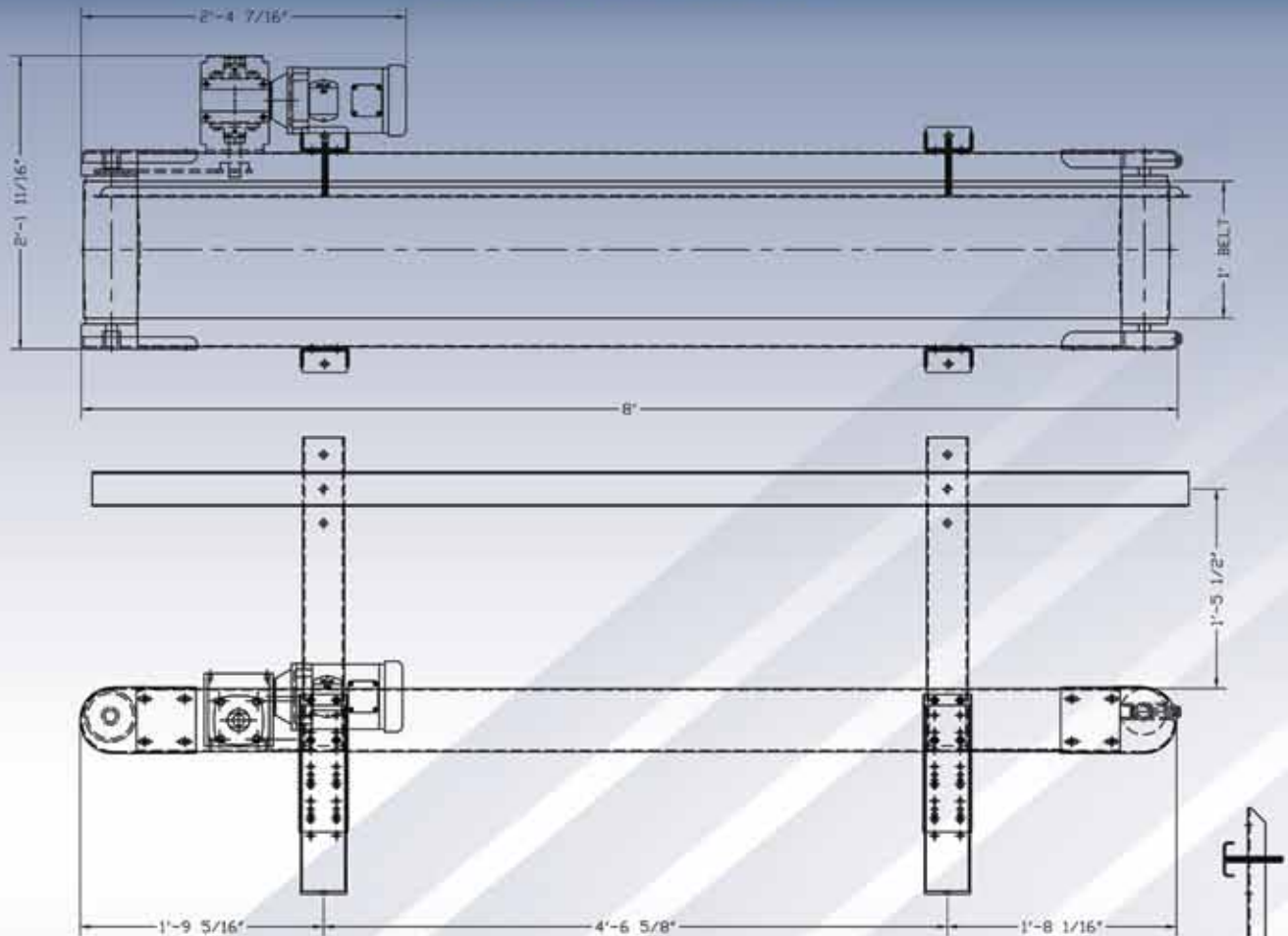

### DESIGN FEATURES:

- ✦ Conveys paper, poly and jute bags.
- ✦ 12" wide conveyor belt.
- ✦ 8' overall standard conveyor length.
- ✦ 35 FPM standard belt speed.
- ✦ Adjustable bag rail full length on backside of conveyor.
- ✦ Lagged drive pulley for maximum belt traction.
- ✦ Supports adjustable for 12"-20" top of belt height.
- ✦ NEMA 12 electrical controls: 230/460 V., 60 Hz., 3 Ph.
- ✦ Formed mild steel slider bed conveyor frame.
- ✦ Industrial enamel finish.



Optional foot operated start/stop switch

### AVAILABLE FEATURES:

- ✦ Manual or electric vertical lift assembly.
- ✦ Lengths and heights to meet specific applications.
- ✦ Supports with locking casters.
- ✦ Foot operated start/stop switch.
- ✦ Variable speed controls.
- ✦ Wash down, corrosive and explosion proof electrical packages.
- ✦ Stainless steel construction.
- ✦ Special finish coatings.

BAG FILLERS

CONVEYORS

PALLETIZERS

SYSTEMS

PO Box 279, Humboldt, Iowa, U.S.A. 50548 / Ph. 515.332.4045 Fax 515.332.1502

[www.chantland.com](http://www.chantland.com)