



CHANTLAND

M H S

Material Handling Solutions

Since
1943



COMPACT WEIGH 4300 OPEN MOUTH GROSS WEIGH FILLER



The Model 4300 is a semi-automatic open mouth gross weigh gravity flow bag filling machine designed to provide fast and accurate filling of open mouth bags with granular free-flowing products such as grains, seeds, dry sand, rock salt and plastic pellets.

SOLUTIONS

WWW.CHANTLAND.COM

BAG FILLERS ♦ CONVEYERS ♦ PALLETIZERS ♦ SYSTEMS

COMPACT WEIGH

4300 OPEN MOUTH GROSS WEIGH FILLER

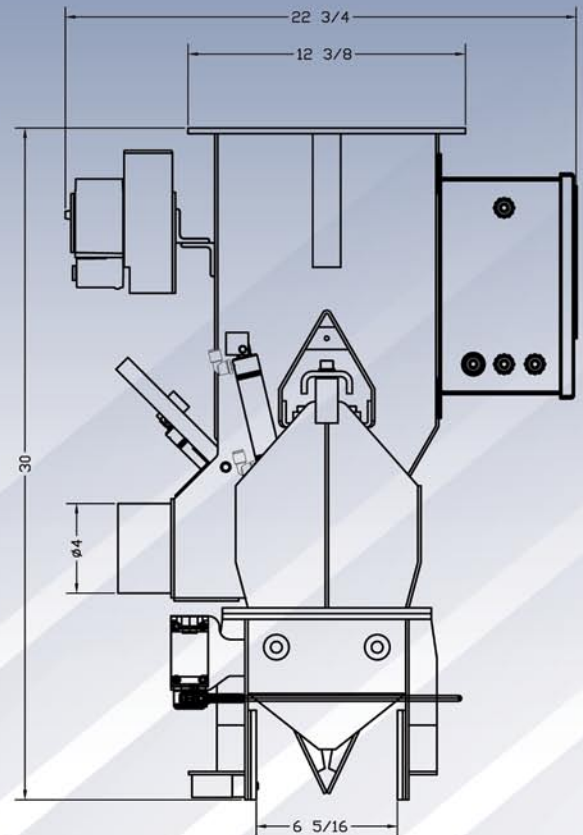
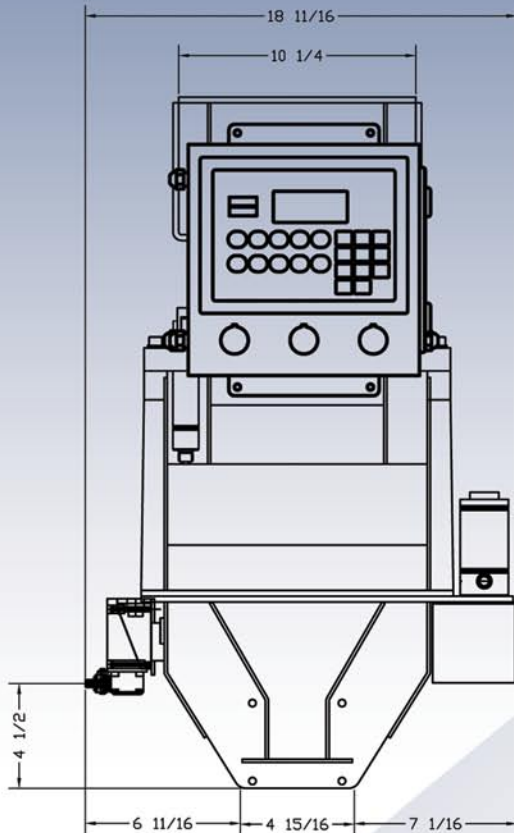

DESIGN FEATURES:

- ◆ Electronic load cell for superior accuracy.
- ◆ Digital scale controls are easy to operate.
- ◆ Bulk flow only.
- ◆ Bulk and dribble flow.
- ◆ Display in either pounds or kilograms.
- ◆ Auto tare.
- ◆ Bag hold switch.
- ◆ Bag in place switch.
- ◆ Bag clamp auto start switch.
- ◆ Auto hold for underweight bags.
- ◆ Calibration routine.
- ◆ Adjustable bulk and dribble flow control gate.
- ◆ 4" diameter dust pickup port.
- ◆ Chantland Blue industrial enamel finish.

STANDARD SPECIFICATIONS:

- ◆ Utility Requirements: **Electrical:** 110 V., 1 Ph., 60 Hz., 3 amp dedicated circuit. **Air:** 2 CFM @ 60-80 PSI, clean and dry.
- ◆ Fill Weights: 20 to 110 lbs.
- ◆ Fill Rates: 10 to 14 bags per minute depending upon product characteristics.
- ◆ Weight Accuracy: +/- 2 oz. depending upon product characteristics.
- ◆ Shipping Weight: 350 lbs.
- ◆ Shipping Crate Dimensions: 31"x31"x36"

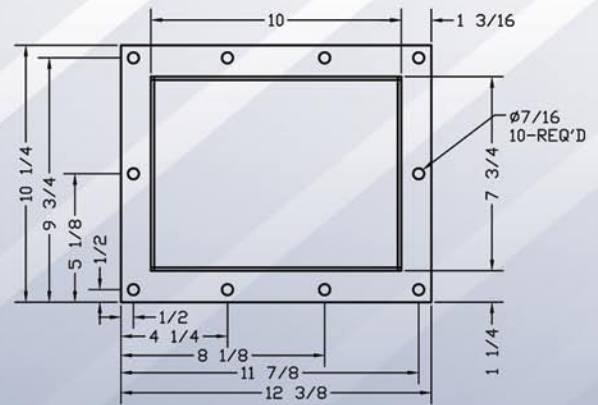

AVAILABLE FEATURES:

- ◆ 316 stainless steel contact surfaces.

BAG FILLERS

CONVEYORS

PALLETIZERS

SYSTEMS

Hwy. 3 East, PO Box 279, Humboldt, Iowa, U.S.A. 50548 / Ph. 515.332.4045 Fax 515.332.1502

www.chantland.com