

# Drawdown Hoppers

## Maximize Active Reclaim



# Outdoor Storage Problems

Outdoor storage problems, including coring and bridging are usually related to compaction resulting from one or more of the following conditions:

- High moisture
- Heat or cold
- Pressure of material on itself
- Compaction caused by bulldozers and other material handling equipment
- Continuous operation of drawdown hoppers



## Coring

Coring occurs when the material in the core of the pile discharges, while material on the periphery resists movement.

## Bridging

Bridging is the archlike formation of material over either the static hopper inlet or outlet. It results from improperly designed hoppers or when the outlet is too small.

Bridging also masks the location of the flow stream, a potentially dangerous condition for on-pile equipment operators.

## Minimal Active Reclaim

By utilizing a static hopper and feeder, active reclaim is limited to within approximately 40 degrees of the stored material's natural angle of repose.

# Carman Drawdown Hopper Solutions

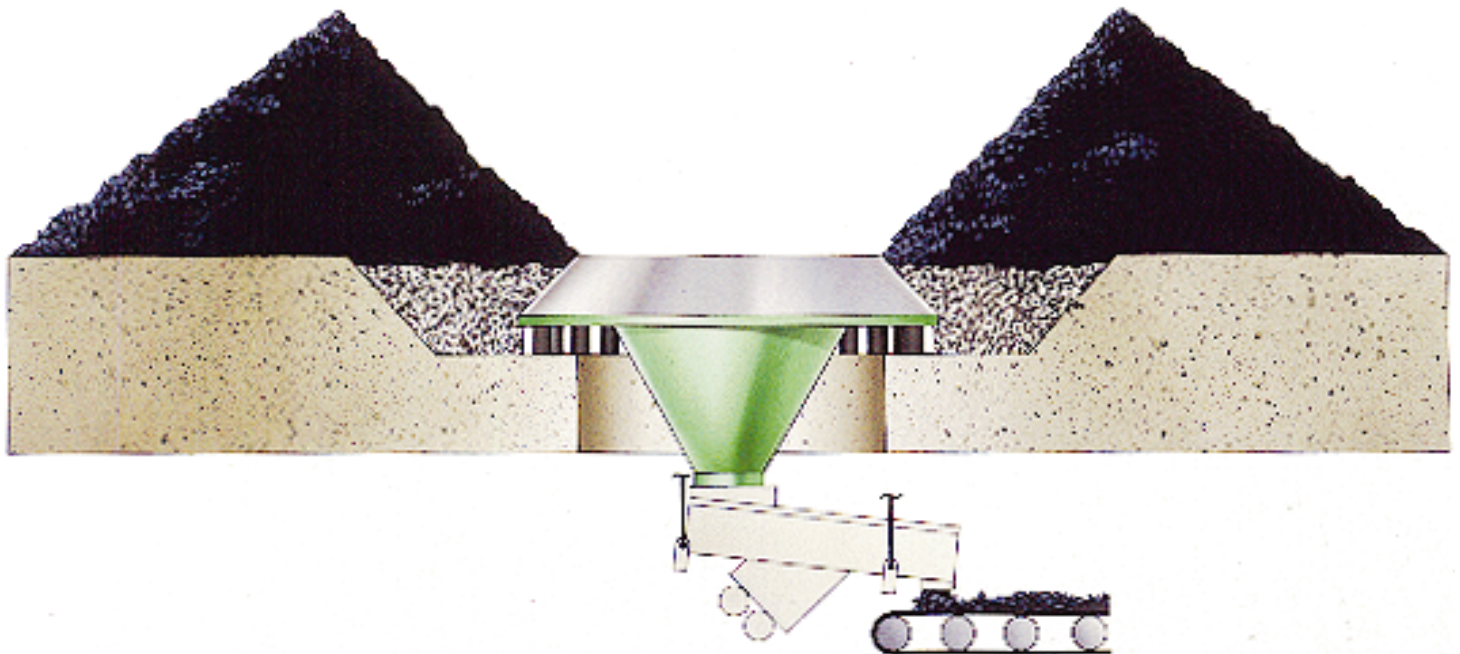

## Eliminate Coring

The projection ring of the Carman Drawdown Hopper, which is always exposed to the pile, transmits vibration and energy directly into the pile. As the central column of flow is drawn down, fracture lines encourage sloughing into the flow stream, eliminating coring.

## Eliminate Bridging

Carman Drawdown Hoppers have command of the material equal to the Drawdown diameter. This results in an initial flow column equal in diameter to the overall diameter of the Drawdown Hopper. A highly visible flow stream also improves on-pile equipment operator safety.

## Maximize Active Reclaim

Carman Drawdown Hoppers consistently increase active reclaim to within 5 to 10 degrees of a material's natural angle of repose. A Carman Drawdown Hopper can provide 4 to 5 times the reclaim of an equally sized static hopper with a feeder.

# The Carman Drawdown Hopper

A unique design with all the hardware to install quickly and the ruggedness to stay on-line.

## Projection Ring

Carman's unique Projection Ring is always in contact with the storage pile. Better flow stimulation and high reclaim percentages result from the controlled transmission of vibratory energy.

## Patented Rubber Isolators

Carman's patented isolation system was developed to support the enormous loads encountered under a storage pile. Specifically designed for use with Drawdown Hoppers, molded rubber isolators are totally non-restraining to allow more motion, more flow stimulation, less power consumption and maximum reclaim. The chamfered top of each isolator allows improved isolation under all conditions from full to no-load.

## Flush Mounting

Flush mounting provides maximum reclaim yet protects from bulldozer, truck or other equipment abuse.

## Steel Skirting/Shield

This exclusive Carman feature is far superior to the skirt-retaining devices used on other units. It not only provides a positive connection to minimize leaks, but also a permanent metal shield to protect (1) the flexible connection from high pressures and (2) the isolation system from build-up and other hazards.

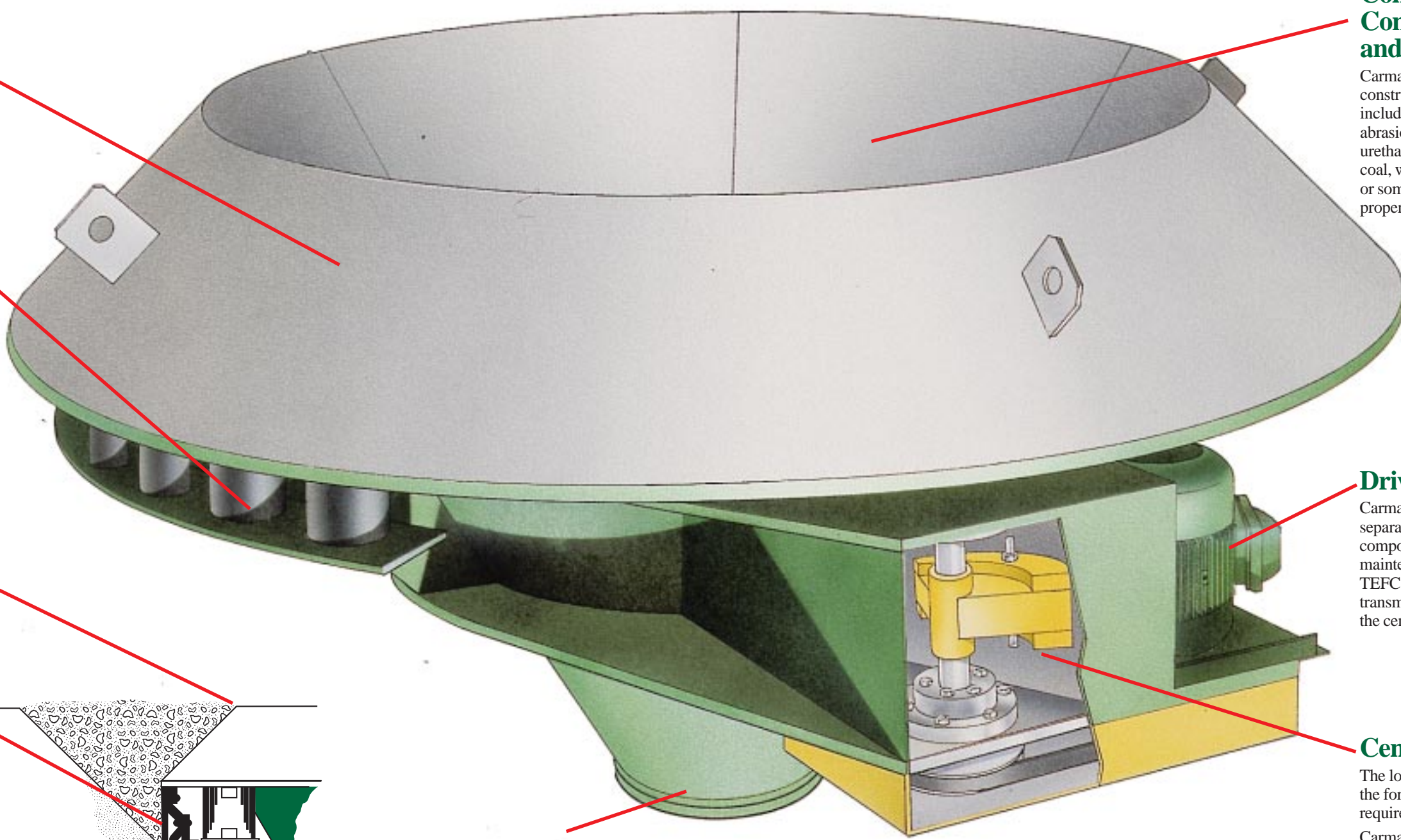

## Complete Range of Construction Materials and Liners

Carman provides a complete range of construction materials and liner choices, including various grades of stainless steel, abrasion resistant steel, epoxy, and urethane. Whether your application is coal, wood, fertilizer, salt, raw ore, tailings or something else, Carman can supply the proper construction materials.

## Drive Motor

Carman's Drawdown Hopper has separate electrical and mechanical drive components for reliability and ease of maintenance. A standard 1800 RPM, TEFC or TEXP foot-mounted motor transmits power through a belt drive to the centrifugal force excitor.

## Centrifugal Force Excitor

The low frequency, long stroke action of the force excitor generates the high energy required for maximum reclaim. Carman's centrifugal force excitor consists of adjustable eccentric weights mounted on a single shaft and supported by bearings. Grease-lubricated double roll spherical bearings assure long life. The excitor is easily accessible for maintenance and serviceability.

## 60 Degree Cone Design

After testing many cone configurations, our 60 degree design has proven to be the most effective for Drawdown Hopper performance. Its 60 degree cone promotes steady flow and eliminates dormant areas associated with other configurations.

## Cycled Operation

Carman's unique design permits cycling of the unit to achieve maximum reclaim. Cycling produces uniform flow, longer excitor life and reduced power consumption.

## Installation Ease

No other reclaim device installs as easily as a Carman Drawdown Hopper - we guarantee it. Our units come absolutely complete, ready to install. All you supply is the crane. Premounted isolators and installation hardware are provided.

# Carman Solutions

Thirty years after Carman's development of the first drawdown hopper, efficient applications can be found in numerous industries throughout the world.



## Problem:

An ore mine was experiencing periodic shutdowns due to an inadequate method of handling mine tailings. Constant attention and excessive manpower was required to permanently dispose of refuse.

## The Carman Solution:

A waste system was installed which included 10 Carman Drawdown Hoppers with reclaim capability of 14,500 tons. The Drawdown Hoppers feed a conveyor system leading to a permanent refuse facility. Shutdowns have been replaced by immediate, uninterrupted flow of refuse material.



## Problem:

An Iowa power company required a reliable active reclaim system which would insure positive flow to fuel preparation equipment.

## The Carman Solution:

Application data was analyzed and four Drawdown Hoppers, symmetrically placed around the stacking tower provide a positive and continuous material source for feeders located in the tunnel. The concrete pads provide a flush, bulldozer-proof installation.

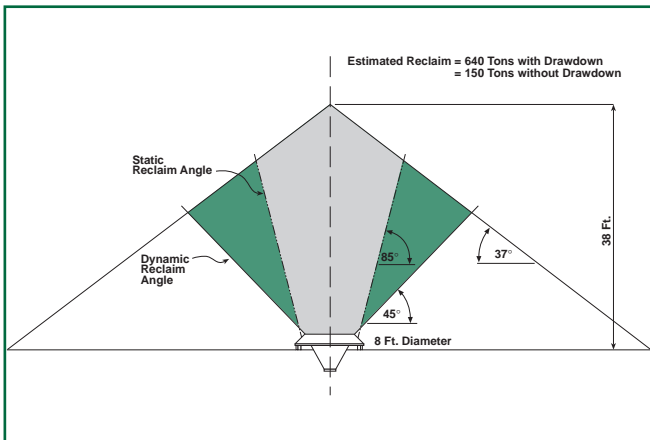

## Problem:

A Colorado company needs accurate modeling to predict the estimated active reclaim of various methods of outdoor storage pile configurations.

## The Carman Solution:

Carman engineers used Carman's exclusive computer program to compare active reclaim capacity of a static hole and feeder to a Drawdown Hopper. Results indicate 400-500% reclaim increases by utilizing a Carman Drawdown Hopper.



## Problem:

A cogeneration facility in North Carolina required maximum reclaim and equipment reliability in the reclamation of coal for boilers.

## The Carman Solution:

Carman recommended two Drawdown Hoppers located on each side of two stacking tubes. Field tests conducted by the customer report the reclaim achieved is nearly identical to that predicted.

# Other Carman Vibratory Equipment

Carman manufactures the most complete line of vibratory material processing equipment in the industry. For more information, call and ask for the bulletin listed under the product you're interested in.

## Adjust-A-Flow Vibrating Feeder



### Feed, Meter, Scalp, Charge or Distribute

- Rugged design well suited for impact loading and handling sticky materials.
- Non-resonant drive.
- Designed and constructed to suit application.
- Isolation system reduces force transmissions.
- Variable capacity control.

Ask for Bulletin No. 610



## Vibrating Fluid Bed Processor



### Heat, Cool, Dry, Classify, Moisturize, Toast, De-Dust, Crystallize or Freeze

- Controlled process air and vibration combine for efficient fluidization.
- Intensive intermixing for direct heat and/or moisture transfer.
- Process flexibility.
- High thermal efficiencies.
- Process Guarantee.

Ask for Bulletin No. 1200



## Vibrating Conveyor



### Convey, Inspect, Orient, Pick, Screen, Clean, Cool, Dry, Feed, Fluidize, Freeze, Heat, Mix, Quench, Size or Sort

- "Natural frequency" spring system.
- "Positive arm" drive.
- Standard-duty, fiberglass leaf spring or heavy-duty coil spring designs available.

Ask for Bulletin No. 700



## Vibrating Bin Discharger



### Eliminate Bridging, Ratholing and Segregation. Maximize Hopper Volume.

- Custom applied hanger arms and internal pressure cone.
- Double clamps eliminate leakage of fine product.
- Long-life vibrating service motor.
- Guaranteed performance.

Ask for Bulletin No. 365

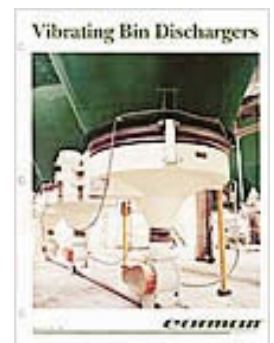

Tip for Printing:

This document uses page sizes optimized for viewing on a computer monitor.

For best printing results, select “Fit to Page” or “Shrink to Fit” from your print menu.

Thank you for considering Carman equipment.

***carman***<sup>®</sup>  
Industries, Inc.